

GEDORE 

PROMOTION

2023

PREMIUM TOOLS / QUALITY MADE BY GEDORE

Prices good through Dec. 31, 2023

Contact Butler Brothers for additional pricing details

GEDORE. Tools for life.

BUTLER BROS.
Since 1952

GEDORE is one of the world's leading producers of premium tools. The family company based in Remscheid Germany has been manufacturing high-quality tools, special tools and tailor-made solutions for versatile, safe and professional use by industry and trade since 1919. GEDORE bundles the competencies of the entire group of companies in a strong brand that is known all over the world to stand for very special quality, innovation, performance, reliability and excellent service. With over 16,000 SKU's, we strive to be your single source for quality tools.

GEDORE. That's over 100 years of forging competence, people who use their knowledge and labor every day to benefit the company and our tools, and entrepreneurial spirit in a recipe for success that has turned the tiny German forge into a family company with an international range.

GEDORE is thrilled to be partnering with the progressive team at Butler Brothers, we look forward to working together to provide you with quality and innovative solutions!

PRECISE IN SHAPE AND TORQUE

NEW!

The GEDORE TORCOFIX is a torque wrench that allows the user almost intuitive operation.

The Torcofix TF-K torque wrench from GEDORE is ideally suited for repair and maintenance work. The ergonomic handle shape centres the hand in the middle of the handle, which is the optimum position for applying force. Thanks to the fixing recesses on the scale frame, there is optimum counter-holding when adjusting the torque. The scale has been optimised by colouring and central positioning of the scale components, which serves to improve the readability and setting of the

torque values. With a release accuracy of $\pm 3\%$ tolerance from the set scale value, the Torcofix exceeds the DIN EN IS 6789-2:2017 requirements of $\pm 4\%$. Due to the durable 1-component handle, the trigger signal can be felt very well. For work in confined spaces, the new Torcofix is also available as an SE variant.

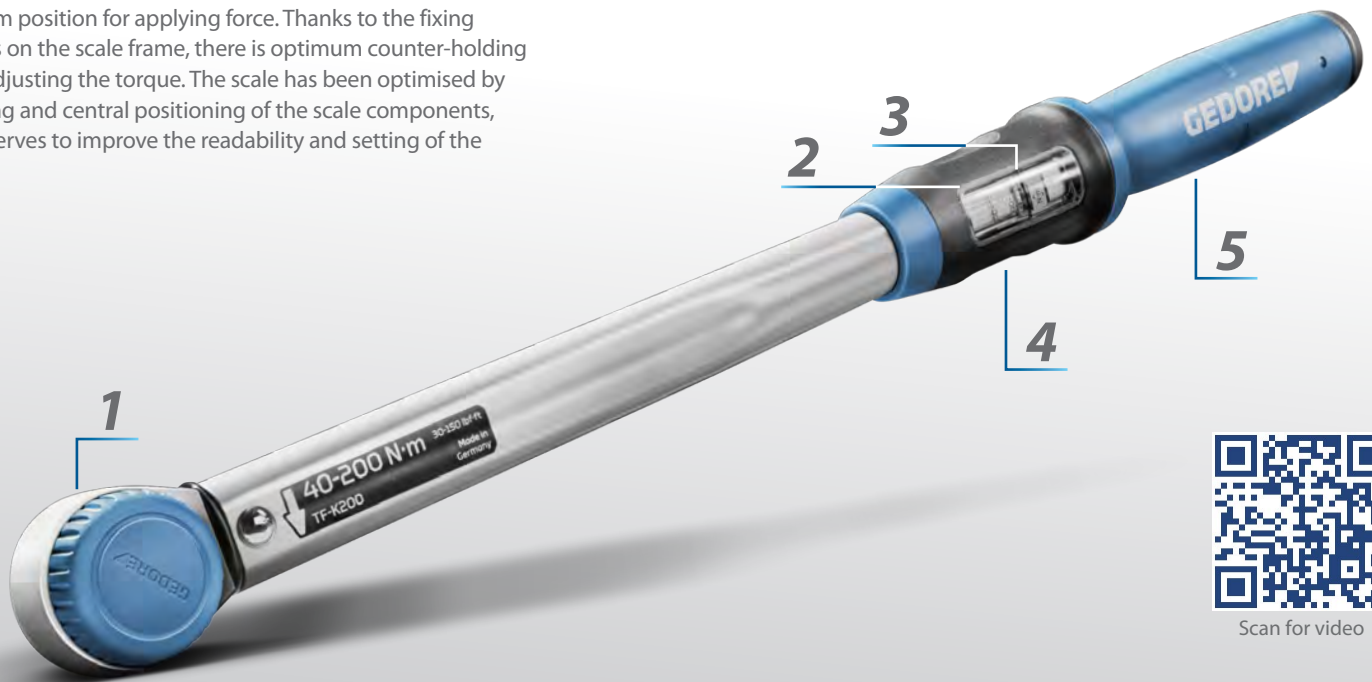

Scan for video

1

CONTROLLED

- Controlled and precise screw tightening from 20-850 N-m
- Deviation of $\pm 3\%$ and thus more precise than the $\pm 4\%$ required by the standard
- Including test certificate according to DIN EN ISO 6789-2:2017

2

IMPROVED READABILITY

- The optimised double scale, the colouring as well as the central alignment of the main scale and vernier ensure better readability of the setting values

3

EASILY READABLE

- Scaling and labeling placed protected under viewing window

4

EASIER TORQUE ADJUSTMENT

- Thanks to the fixing recesses on the scale frame, there is optimum counter-holding during torque adjustment

5

INTUITIVE, ERGONOMIC APPLICATION

- The ergonomic handle shape centers the hand in the middle of the handle
- Clearly audible and perceptible torque release



Prescribed tightening torques for almost all fastening connections - from stem, to brakes, to drive - can be precisely adhered to with the Torcofix. For the highest bolting quality.

TF-K TORQUE WRENCH TORCOFIX TF-K

20-850 N·m / 15-630 lbf·ft



Use:

- > Controlled screw tightening in the most common range of 20 - 850 N·m / 15 - 630 lbf·ft
- > Adjustable, releasing and sturdy tubular torque wrench with integrated ratchet and with square drive for industry and the trades

Features:

- > Classified as per DIN EN ISO 6789-2:2017 Type II Class A; adjusted to a maximum permissible +/-3% deviation and thus with a greater precision than the standard-stipulated +/-4%
- > incl. traceable test certificate (DIN EN ISO 6789-2:2017)
- > For controlled bi-directional tightening
- > 1/2" mushroom head square with ball lock. From 3/4" with square socket and pin retention
- > Robust, matt powder-coated tubular steel construction, with galvanized ratchet and high-quality plastic parts
- > New ergonomic handle, shaped according to the natural grip position of the hand
- > clearly recognisable and tactile hand centring aid and calibration aid in the middle of the handle
- > Double scale N·m / lbf·ft and vernier are protected from abrasion and contamination by an enlarged viewing window
- > With vernier scale for N·m main scale for setting intermediate scale values; lbf·ft setting only via main scale
- > Vertical alignment of the scale, torque adjustment therefore suitable for left and right handers
- > Scale line positioned directly above the scale prevents reading errors (parallax errors)
- > Unit inscription integrated in the scale frame and also protected against abrasion via viewing window,
- > Precise mechanism generates a clearly perceptible and audible trigger signal when the set torque value is reached
- > incl. roll away protection, prevents rolling away when the tool is put down

Code	No.	Drive square inch	lbf·ft	N·m	Scale Division	vernier Nm	Length mm	Price	Promotion Price
3278379	TF-K100	1/2"	15-75	20-100	5 N·m	0.5 N·m	313.3	228.00	205.00
3278387	TF-K200	1/2"	30-150	40-200	10 N·m	1 N·m	404.3	242.50	218.00
3278395	TF-K300	1/2"	45-220	60-300	10 N·m	1 N·m	495.3	295.00	265.00
3278409	TF-K400	3/4"	60-300	80-400	10 N·m	1 N·m	593.3	495.00	445.00
3278492	TF-K550	3/4"	80-405	110-550	10 N·m	1 N·m	863.8	795.00	715.00
3278514	TF-K850	3/4"	185-630	250-850	10 N·m	1 N·m	1285.8	1055.00	949.00

TF-Z TORQUE WRENCH TORCOFIX TF-Z

5-850 N·m / 3,7-630 lbf·ft

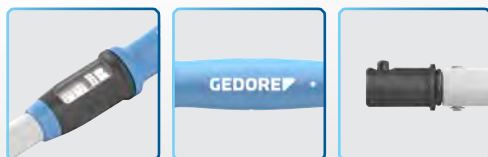

Use:

- > Controlled screw tightening in the most common range of 20 - 850 N·m / 15 - 630 lbf·ft
- > Adjustable, releasing and sturdy tubular torque wrench with spigot end for industry and the trades

Features:

- > Classified as per DIN EN ISO 6789-2:2017 Type II Class A; adjusted to a maximum permissible +/-3% deviation and thus with a greater precision than the standard-stipulated +/-4%
- > incl. traceable test certificate (DIN EN ISO 6789-2:2017)
- > For controlled right- and left-hand tightening (change tool for changing direction)
- > Trunnion mounting in the versions Ø 16 mm and Ø 22 mm
- > Factory depth gauge: 32 mm (Ø 16 mm) or 56 mm (Ø 22 mm)
- > Robust, matt powder-coated tubular steel construction, with galvanized ratchet and high-quality plastic parts



310,3 - 1276,8 mm



Code	No.	Ø	N·m	lbf·ft	Scale Division	vernier Nm	Length mm	Price	Promotion Price
3278573	TF-Z100	16	20-100	15-75	5 N·m	0.5 N·m	310.3	185.00	165.00
3278581	TF-Z200	16	40-200	30-150	10 N·m	1 N·m	401.3	215.00	193.00
3278603	TF-Z300	16	60-300	45-220	10 N·m	1 N·m	492.3	256.00	230.00
3278611	TF-Z400	16	80-400	60-300	10 N·m	1 N·m	582.3	365.00	330.00
3278638	TF-Z550	22	110-550	80-405	10 N·m	1 N·m	848.8	650.00	585.00
3278654	TF-Z850	22	250-850	185-630	10 N·m	1 N·m	1276.8	980.00	882.00

TORQUE MULTIPLIERS



DVI-28
TORQUE MULTIPLIER
DREMOPLUS ALU
 2800 N·m / 2050 lbf·ft

Especially suitable for:

- › Industry, construction sites, commercial vehicle and car workshops, agricultural technology, construction machinery
- › Bridge, ship, aircraft and railway construction, refineries
- › Output square with hole for Impact sockets with locking pin and ring



Scan for video



Code	No.	Output torque (max.) N·m	Output torque (max.) lbf·ft	Multiplication ratio	Version reaction arm	Output square (inch)	Price	Promotion Price
2653257	DVI-28L	2800	2050	1:5.5	L-Form, straight	1"	4,598.00	4,150.00
2653273	DVI-28Z	2800	2050	1:5.5	Z-Form, cranked	1"	3,345.00	2,995.00

TORQUE TESTING & VALIDATION

8612-300

ELECTRONIC TORQUE TESTER DREMOTEST E

9-320 N·m / 7 lbf·ft - 236 lbf·ft

- › For checking or adjusting right-hand torque wrenches and torque screwdrivers, ideal for checking fixed torque wrenches on the line
- › High measurement accuracy:
+/- 1% tolerance of reading, +/- 1 digit
- › Peak value detection (first peak / crack detection)
- › Can be switched from N·m to lbf·ft and lbf·in

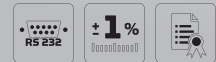

Code	No.	N·m	lbf·ft	Drive connector hexagon female (metric)	Resolution	Adaptor	Price	Promotion Price
1856111	8612-300	9 N·m - 320 N·m	7 lbf·ft - 236 lbf·ft	17.0	1	3/8", 1/2"	2,2150.00	1,590.00

CAPTURE LITE

- › The latest edition to the Gedore Capture range is Capture Lite.
- › A robust Torque tester for use in Industrial, automotive and production environments.
- › Suitable for use with clicker breaking and slipping wrenches and torque screwdrivers.



Scan for video



The robust construction with aluminum anodized body ensures long tool life. OLED display, safely housed under a robust Perspex screen protector allows for a compact design. Capture Lite's contemporary & high-quality appearance means that it is appropriate and well adapted for use in high technology & manufacturing environments.

Capture Lite's power and data links via the USB port located at the rear of the device allowing data to be exported if required.

The Torque tester is easy to operate and can be used by operators at any skill level. Clear to read display gives the operator a quick and efficient method for checking their tools. Designed to give the user confidence that their Torque tools are operating within limits. Capture Lite has three modes: Peak—displaying the highest torque value reached, First Peak—displaying the first peak torque value & Track—progressively tracks the applied torque. To protect the Capture Lite when not in use it is supplied with a protective carry case and USB power cable.

Code	No.	Description	Price	Promotion Price
028120AE2610	CL10 SP	CaptureLite CL10 Torque Tester, 4 - 88 lbf·in / 0.45 - 10 Nm (Special Color Edition), ¼" F/Square Drive, +/- 1% Accuracy	1,650.00	895.00
038120AE2610	CL350	CaptureLite CL350, Torque Tester 7 - 258 lbf·ft / 10 - 350 Nm 3/8" M/Hex Drive, +/- 1% Accuracy	1,650.00	895.00

PRECISION TO PERFECTION

The GEDORE TSN SLIPPER TSN 25 D torque wrench is the torque wrench for maximum accuracy, as required in series or assembly line assembly.

The finely adjustable TSN Slipper with 1/4" socket is the professional choice for specified controlled screw tightening from 5 - 25 Nm. The torque can be set at the factory or by the user with a tester. The achievement of the torque is clearly noticeable and audible signaled. Overtightening is not possible with this torque wrench.

Due to the technology and the fixed setting of the torque, this torque wrench is optimally suited for series production. Designed for extreme continuous use, it impresses not only with its impeccable workmanship, but also with the highest accuracy and a handling that supports this use over a long period of time. This is achieved, among other things, by the light but stable and corrosion-resistant construction.

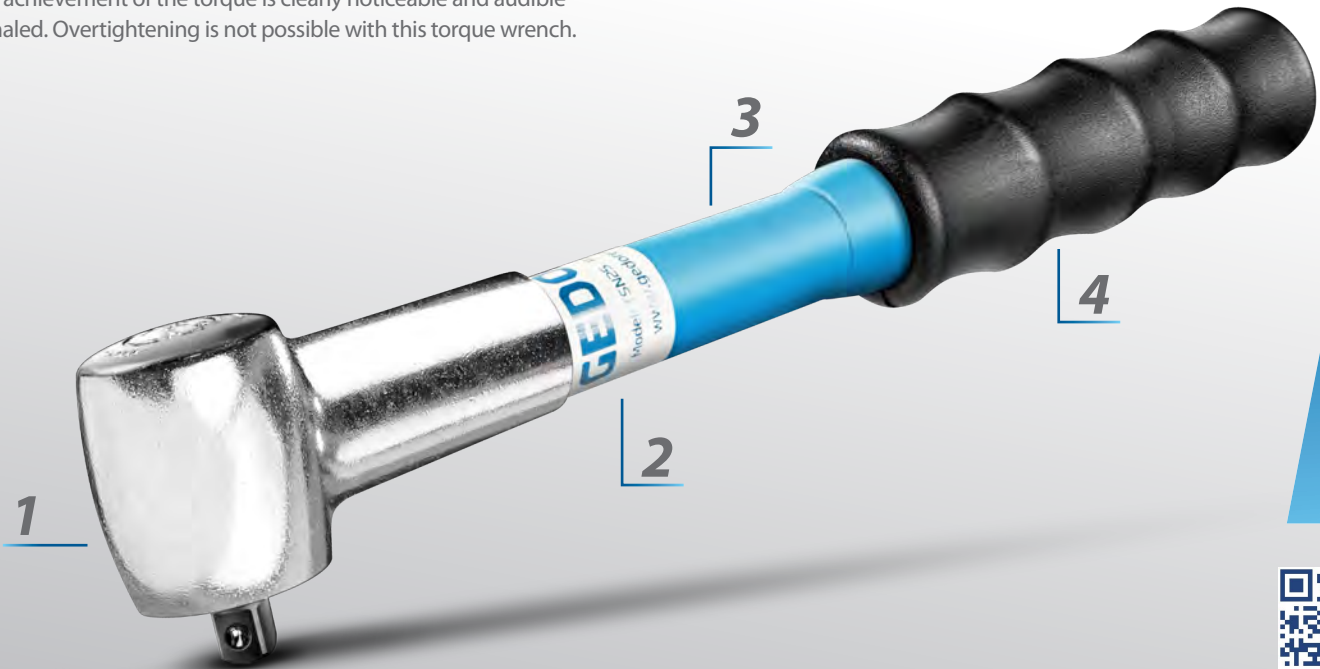

Scan for video

TSN TORQUE WRENCH TSN SLIPPER

5-25 N·m / 44-221 lbf·in / Fixed setting



- > Pre-set production torque wrench - without scale
- > 1/4" and 3/8" square drive with ball lock
- > For controlled directional tightening
- > Over tightening of the screw is not possible
- > Acc. to DIN EN ISO 6789, traceable to national standards
- > Precision mechanism slides through clearly noticeable and audible (CLICK and slip) when the set value is reached - overtightening is not possible
- > Automatic resetting to the starting position
- > Lightweight, but robust and corrosion-resistant construction design



Code	No.	Type	Square drive inch	Square drive metric mm	N·m	Length mm	Price	Promotion Price
7091900	TSN 25 D	Single square ratchet	1/4"	6.3	5-25	216	764.80	688.00
7092040	TSN 25 A	Single square ratchet	3/8"	10	5-25	216	764.80	688.00

1

ABSOLUTE ACCURACY WITHOUT OVERTIGHTENING

- The unique slipping technology prevents overtightening of the screw joint and thus ensures safety in the screwdriving process.

2

EPA COMPLIANT

- Ideal for safe assembly and maintenance of electronic components as this tool is EPA compliant. Designed for use in electrostatic sensitive areas.

3

IMPROVED PRODUCTION EFFICIENCY

- The fixed torque setting prevents adjustment errors and ensures a speedy workflow.

4

LONG SERVICE LIFE

- High-quality design and robust construction guarantee a long service life.



The TSN SLIPPER TSN 25 D enables durable work with precision at the very highest level.



i FIXED SETTING

FUNCTIONAL PRINCIPLE

When the fixed value is reached, the mechanism slips over the ball (without the possibility of over tightening). The torque wrench is then immediately ready for use again.

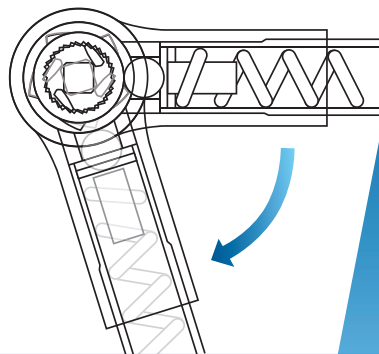

TECHNIQUE

All torque wrenches are adjusted in value via a patented slipping/ cam-over mechanism in conjunction with an appropriate testing device.

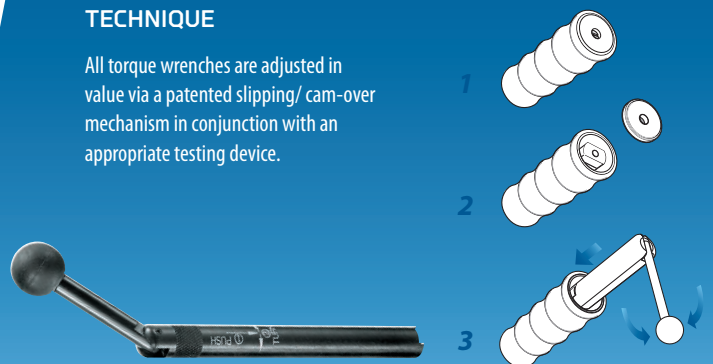

QS 6 FH BLUE TORQUE SCREWDRIVER

1-6 N·m



Scan for video



- > Adjustable torque screwdriver - with scale
- > 1/4" hexagon socket for 1/4" bits - C 6.3
- > With adaptor also suitable for 1/4" square drive sockets as per DIN 3124
- > Over tightening of the screw is not possible
- > Acc. to DIN EN ISO 6789, traceable to national standards
- > Test certificate acc. to DIN EN ISO 6789
- > Precision radial ball clutch and cam design for controlled bi-directional tightening

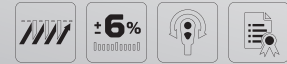

Code	No.	Output piece inch	N·m	Total length mm	Price	Promotion Price
7718130	QS 6 FH BLUE	1/4"	1-6	184	510.00	460.00

PRO 450 FH TORQUE SCREWDRIVER TYPE PRO FH

0.5 - 4.5 N·m / fixed setting



- > Fixed torque screwdriver for series assembly
- > 1/4" hexagon socket for 1/4" bits - C 6.3
- > With adaptor also suitable for 1/4" square drive sockets as per DIN 3124
- > Over tightening of the screw is not possible
- > Test certificate according to DIN EN ISO 6789, permissible deviation of +/- 6 %.
- > Precision mechanism slides through clearly noticeable and audible (CLICK and slip) when the set value is reached - overtightening is not possible
- > Automatic resetting to the starting position
- > Fatigue-free work due to ergonomic handle
- > Lightweight, but robust and corrosion-resistant construction design



Code	No.	Drive square inch	Drive mount metric mm	N·m	Total length mm	Price	Promotion Price
2927772	PRO 450 FH	1/4"	6.3 mm	0.5-4.5	140	190.00	170.00

QSN TORQUE SCREWDRIVER TYPE QSN

0,08-9 N·m



Scan for video



- > Adjustable torque screwdriver - with scale
- > 1/4" hexagon socket for 1/4" bits - C 6.3
- > With adaptor also suitable for 1/4" square drive sockets as per DIN 3124
- > Over tightening of the screw is not possible
- > Test certificate acc. to DIN EN ISO 6789
- > Lightweight, but robust and corrosion-resistant construction design
- > Test certificate acc. to DIN EN ISO 6789
- > Models No. QSN600 FH QSN900 FH additional cross handle



Code	No.	Drive mount inch	Drive mount metric mm	Output piece inch	N·m	Total length mm	Price	Promotion Price
1498738	QSN 40 FH	1/4"	6.3	1/4"	0.08-0.4	159	593.00	533.70
1400150	QSN 120 FH	1/4"	6.3	1/4"	0.2-1.2	183	598.00	540.00
1400169	QSN 600 FH	1/4"	6.3	1/4"	1-6	196	611.00	550.00
1400177	QSN 900 FH	1/4"	6.3	1/4"	4-9	196	611.00	550.00

1100-1.30
**INTERNAL
 EXTRACTOR SET**
 in L-BOXX® 136, 8-pieces



- › For inner diameter 12 - 35 mm
- › For extremely-tightly-packed ball bearings, bearing races, bushings, and shaft seals Simmering®
- › With slide hammer and counter support

Code	No.	Contents	Length mm	Width mm	Depth mm	Pieces	Price	Promotion Price
2836041	1100-1.30	Internal extractor No. 1.30/2.12-15 mm Internal extractor No. 1.30/3.15-19 mm Internal extractor No. 1.30/4.19-25 mm Internal extractor No. 1.30/4A, 25-30 mm Internal extractor No. 1.30/45, 30-35 mm Counter support No. 1.36/1 for 1.30/0 - 1.30/5 Sliding hammer No. 1.35/2, 500 mm, 1.7 kg + GEDORE L-BOXX® 136 No. 1100 L	357	442	151	8	675.00	607.00

1100-1.41/2A
**SEPARATOR
 AND PULLER SET**
 in L-BOXX® 136, 22 pieces



- › For clamping depths from Ø 22 to 115 mm and clamping reach up to 295 mm
- › Incl. threaded inserts for internal threads M8-M18
- › For loosening and pulling tightly-seated parts e.g. taper roller bearings and inner bearing races

Code	No.	Contents	Max. Span mm	Length mm	Width mm	Depth mm	Pieces	Price	Promotion Price
2927284	1100-1.41/2A	Separator puller No. 1x 1.38/2, 70-215 mm Separator No. 1.40/2, 22-115 mm Set of threaded inserts No. 1.81/20, for 1 and 2-hole applications, M14x1.5 2x extension No. 1.38/CV M14x1.5 + GEDORE L-BOXX® 136 No. 1100 L	115	357	442	151	22	811.00	730.00

ONE TOOL, THREE SIZES

With its slender hooks of different lengths, the two-arm puller has been specially designed for tight spaces.

With a clamping depth of up to 250 mm, this puller is particularly flexible in use. The maximum pulling force is 2.5 t. This makes the GEDORE puller particularly suitable for use in the automotive/automotive sector. The spindle, with a thread size of M 14x1.5 x 140, has an operating hexagon of SW 17, which means that this puller can be operated with robust combination wrenches or with a ratchet and 17 mm insert. Due to the special coating, the spindle is maintenance-free. There is no contamination of the threads as with greased spindles. The very slim designed hooks allow the work on difficult to access places.

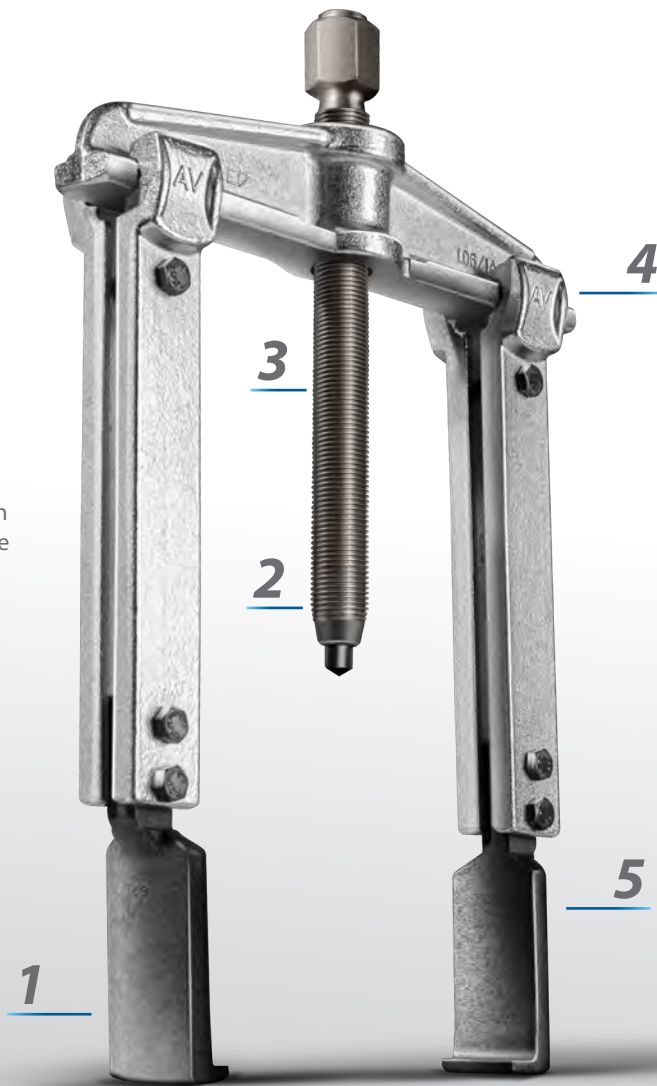

Scan for video

1.06/AS PULLER-SET with 6 legs



- > Particularly suitable for barely accessible places
- > Particularly suitable for hard-to-reach areas

Code	No.	Contents	Max. Usable clamping depth mm	Max. Span mm	Hook foot thickness mm	Total hook base depth mm	Pieces	Price	Promotion Price
8001710	1.06/AS	106/1A03 Cross beam 2-arm 180 mm 106/A-100-S Pull-off hook slim 100 mm (2x) 106/A-200-S Pull-off hook slim 200 mm (2x) 106/A-250-S Pull-off hook slim 250 mm (2x) E-1.1406140 Spindle SW 17, M14x1.5, 140 mm	100 / 200 / 250	130	3.7	13.5	8	598.00	540.00

1

BLACK HOOKS

- The slim hooks are specially made for use in hard-to-reach places.

2

MAINTENANCE-FREE

- The special coating makes the spindle maintenance-free. There is no contamination of the threads as with greased spindles.

3

STRONG SPINDLE

- The spindle with the thread size M 14x1.5 x 140 has an actuating hexagon of SW 17.

4

THREE DIFFERENT SIZES

- The puller comes with 6 arms in three different lengths: 100 mm, 200 mm and 250 mm.

5

HIGH LOAD CAPACITY

- The puller has a maximum pulling force of 2.5 t.



Flexibility with the 3 lengths to meet any specialized application.



1.31/2
INTERNAL EXTRACTOR SET
10 pieces



- › Set of the most common internal extractors and counter supports for extracting ball bearings, rings, bushings, Simmerrings®, etc.
- › In robust sheet metal case

Code	No.	Contents	Span inside pull-off min./max.	Pieces	Price	Promotion Price
8014880	1.31/2	1.30/2 Internal extractor 12-15 mm, 1.30/3 Internal extractor 15-19 mm 1.30/4 Internal extractors 19-25 mm, 1.30/4A Internal extractors 25-30 mm 1.30/5 Internal extractors 30-35 mm, 1.30/6 Internal extractors 35-45 mm 1.30/7 Internal extractor 45-55 mm, 1.30/8 Internal extractor 55-70 mm 1.36/1 Counter support for 1.30/0 - 1.30/5, 1.36/2 Counter support for 1.30/6 - 1.30/7, 131/299B Sheet metal box empty	12-70	10	875.00	785.00

Price 4,598.00 Promotion Price 4,598.00

1.32/1 SET OF INTERNAL AND EXTERNAL EXTRACTORS

11 pieces

\$ 965.00



- › This set is ideally suited for a variety of exterior and interior stripping situations
- › Sets with internal extractors, counter supports, puller chucks, external extractors and stud extractors
- › In robust sheet metal case

Code	No.	Contents	Pieces	Price	Promotion Price
8015260	1.32/1	1.30/2 Internal extractor 12-15 mm, 1.30/3 Internal extractor 15-19 mm 1.30/4 Internal extractors 19-25 mm, 1.30/4A Internal extractors 25-30 mm 1.30/5 Internal extractor 30-35 mm, 1.30/6 Internal extractor 35-45 mm 1.36/1 Counter support for 1.30/0 - 1.30/5, 1.36/2 Counter support for 1.30/6 - 1.30/7 1.19/OXS Puller 3-arm XS hook 50x70 mm, 1.12/02 Pole terminal puller 2-arm 60x40 mm 1.06/1 Universal puller 2-arm 90x100 mm, 132/199B Sheet metal box empty	11	965.00	870.00

1.26 NUT SPLITTER

from \$103.00 VAT



- › For splitting jammed or stripped nuts without damaging the bolt thread
- › For nuts up to property class 6
- › With chisel stopper

Code	No.	For nuts of size	Spindle thread size	Width across flats mm	Weight kg	Price	Promotion Price
8009880	1.26/1	M6 - M10	M14x1,5	17	0.27	103.00	92.50
8009610	1.26/2	M10 - M16	M 14x1,5	17	0.3	123.00	110.00
8010030	1.26/3	M16 - M24	M 22x1,5	24	1.13	159.00	145.00

1.81/10 THREAD ADAPTOR SET

for 1- and 2-hole applications,
2 pieces each, 14 pieces

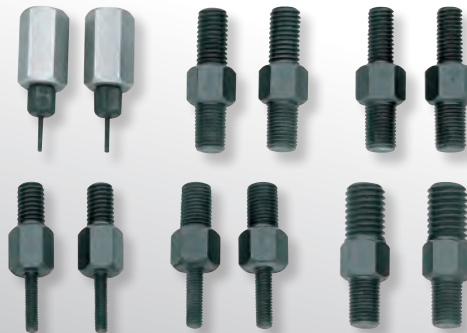

- › The threaded inserts make the removal of threaded caps, for example, possible, when these possess 1 or 2 threaded holes
- › No. 1.81/10: For puller No. 1.38/0, 1.38/1
- › Can be used either with puller 1.38, slide hammer 1.35 or counter support 1.36

Code	No.	Contents	Pieces	Price	Promotion Price
1120735	1.81/10	2 Thread inserts M14x1,5 - M8, No. 181/207, 2 Thread inserts M14x1,5 - M10, No. 181/208 2 Thread inserts M14x1,5 - M12, No. 181/209, 2 Thread inserts M14x1,5 - M14, No. 181/210 2 Thread inserts M14x1,5 - M16, No. 181/211, 2 Thread inserts M14x1,5 - M18, No. 181/212, 2 Adaptors, No. 181/225	14	175.00	160.00

1.81/K-1
**THREAD
 ADAPTOR SET**
 for 1-hole applications,
 7 pieces



- › The threaded inserts make the removal of threaded caps, for example, possible, when these possess one threaded hole
- › Can be used either with slide hammer 1.35 or optionally with counter support 1.36

Code	No.	Contents	Length mm	Width mm	Height mm	Pieces	Price	Promotion Price
1936549	1.81/K-1	Slide hammer 1.35/1 Rod 230 mm Impact weight 200 g M10 - M4, M10 - M5, M10 - M6 M10 - M8, M10 - M10, M10 - M12	270	230	84	7	178.00	160.00

1.41/1
**SEPARATOR
 AND PULLER SET**



- › For Ø 12-75 mm all in one, separator extractor extensions in handy case to take with you
- › Optimal for tightly mounted/ abutting parts
- › Additional extensions 1.38/CV optionally available

Code	No.	Contents	Price	Promotion Price
8109830	1.41/1	1.38/1 Extractor 60-165 mm 1.38/AV Extension M10 (pair) 1.40/1 Separating device 12-75 mm, 141/099B Sheet metal box empty	307.00	276.00

THE PERFECT INITIAL EQUIPMENT

7-way adjustable, extra narrow pliers jaws - the GEDORE water pump pliers 145 10 JC are impressive with its flexibility and high-quality workmanship.

The slim design is made possible by the attached joint which, with its toothed recess, opens up the variable adjustment possibilities and, with its self-clamping properties, provides particular support when gripping pipes and nuts. Made of chrome vanadium special steel and inductively hardened at crucial points (jaws, teeth), these pliers are an indestructible

helper even in demanding use in trade and industry. The ergonomic 2-component handles make the pliers easy to handle and protect tendons and joints, especially during prolonged use.



NEW



Scan for video

145 10 JC WATER PUMP PLIERS

- > Acc. to DIN ISO 8976 Form A
- > Lay-on slip joint and toothed recess
- > Induction-hardened serrated faces, with protection against blocking
- > Clamps automatically on pipes and nuts
- > GEDORE special chrome-vanadium steel, chrome-plated
- > Version JC = with 2-component handles
- > 7-way adjustable, with extra narrow jaws



Code	No.	Clamping reach mm	Length mm	Price	Promotion Price
6415610	145 10 JC	39	260	53.60	45.00

1

BEST PROCESSING

- The pliers are forged from chrome-vanadium special steel and chrome-plated. The teeth are additionally inductively hardened.

2

ERGONOMIC HANDLES

- The ergonomic 2-component handles lie securely in the hand and ensure pleasant handling, even over a longer period of time.

3

SLIM DESIGN

- The mounted joint and the flat jaws jaws allow for an extremely slim, compact design of the pliers.

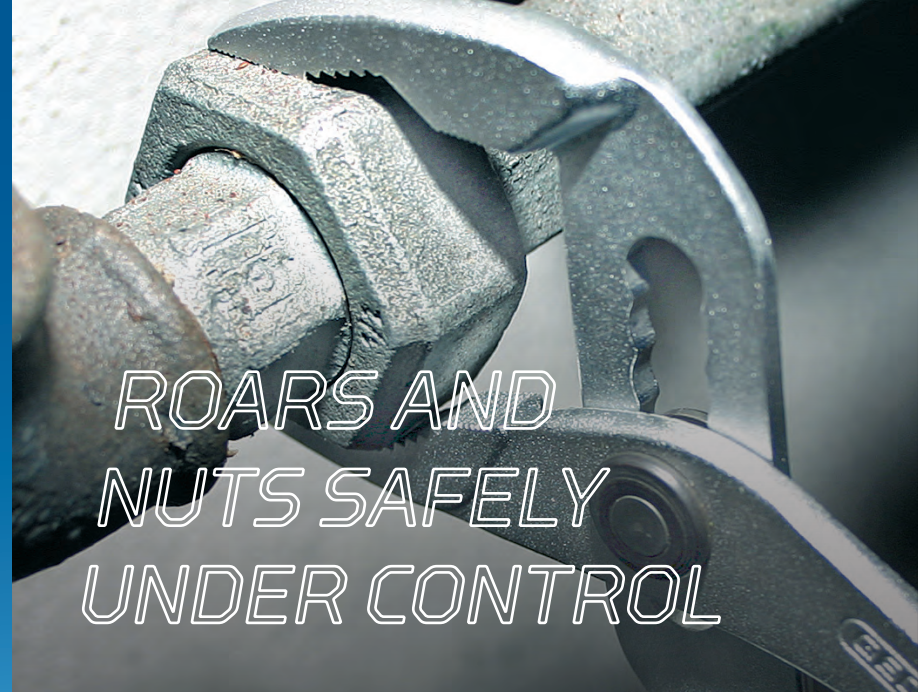

ROARS AND
NUTS SAFELY
UNDER CONTROL

The GEDORE water pump pliers 145 10 JC is designed to be flat and compact, thereby making it possible grip nuts and bolts where space is at a premium.



8133-180 JC MULTIPLE PLIERS

with cutting edge, serrated,
straight pattern



- > Multifunctional pliers for the mechanical and electronic fields
- > Suitable for holding, bending, cutting, stripping, crimping and squeezing different materials
- > For medium-hard wire 1.6 mm
- > Fatigue-free work in continuous use thanks to the ergonomic 2-component handle
- > Additional induction hardened precision cutting edges, cutting edge hardness 62-64 HRC
- > GEDORE special hardened and tempered steel, drop-forged, oil-hardened and annealed
- > For stripping cables from 0.5 to 2.5 mm²
- > Cutting edge additionally induction hardened
- > Version JC = chrome-plated, with 2-component handles

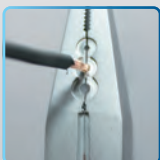

Code	No.	Total length mm	Price	Promotion Price
6722110	8133-180 JC	180	59.00	49.00

VERSATILE AND PRACTICAL



S 8008
SET OF CIRCLIP PLIERS
 8 pieces

- > Practical set composition in environmentally-friendly cardboard box
- > Particularly suitable for hard-to-reach areas
- > For internal and external retaining rings
- > With straight and 90° angled tips



Code	No.	Contents	Length mm	Width mm	Height mm	Pieces	Price	Promotion Price
6700490	S 8008	8000 A 1 11 2 21 8000 J 1 11 2 21	315	156	30	8	240.00	215.00

1090

TOOL CASE ELECTRICIAN

87 pieces

- > The perfect tool set for the electrician or property manager
- > In a sturdy hard case made of impact-resistant ABS plastic
- > GEDORE vanadium tools, chrome-plated



6,3 1/4" mm

Code	No.	Contents	Length mm	Width mm	Height mm	Pieces	Price	Promotion Price
6601590	1090	Double open-end spanner No. 6 14x17 18x19 21x23 22x24 Double open end spanner set 11 pcs No. 8-011 4,5-13mm Socket spanner set 1/4" 40pcs No. D 20 TMU-10 UD-IN-IS-PH-PZ-TX Offset screwdriver set in holder 10pcs No. H 42-10 1.3-10mm Pliers spanner 10" 183 10 TC VDE Screwdriver SLIM DRIVE Cross-recess PZ 1 VDE 2162 PZ 1 VDE Screwdriver SLIM DRIVE Cross-recess PZ 2 VDE 2162 PZ 2 VDE Screwdrivers SLIM DRIVE Cross-recess PH 1 VDE 2162 PH 1 VDE Screwdrivers SLIM DRIVE Cross-recess PH 2 VDE 2162 PH 2 VDE Screwdriver SLIM DRIVE slotted 3.5mm VDE 2172 3.5 VDE Screwdriver SLIM DRIVE slotted 4mm VDE 2172 4.0 VDE Screwdriver SLIM DRIVE slotted 5.5mm VDE 2172 5.5 VDE Screwdriver SLIM DRIVE slot 6.5mm VDE 2172 6.5 Hobby saw 406 Carbide scriber 746 Cable knife 4528 Steel tape measure 3 m 4534-3 Voltage tester 2-pole 1000V LED display VDE 4616 VDE Stripping pliers 160mm VDE 8098-160 H VDE Power combination pliers 180mm VDE 8250-180 H VDE Multi-purpose pliers 200mm VDE 8131 AB-200 H VDE Power side cutters 200 mm VDE 8316-200 H Flat chisel flat oval 95-175 ROTBAND-PLUS fitter's hammer with hickory handle, 300 g 600 H-300 Switch cabinet spanner Universal 45 S Volume tool case empty WK 1041 L	370	480	180	87	1,590.00	1,450.00

THE INSULATED ALL-ROUND PACKAGE

The intelligent set, tuned for hybrid and electric mobility manufacturing and repair.

The perfect set, perfectly housed. The hand tools for repair and maintenance work on hybrid and electric vehicles from all manufacturers, stowed in the GEDORE L-BOXX® 136, compatible with the Sortimo® in-vehicle equipment in your service van, leaves nothing to be desired. The set represents an ideal initial equipment, but also a very good addition to existing equipment. The VDE HYBRID tool set from GEDORE includes, among other things, the 3/8" VDE reversible ratchet with VDE sockets SW 6 - 22 and numerous accessories, a VDE pliers set and a large VDE screwdriver set, as well as special tools. All tools are insulated according to EN 60900/EC 60900, i.e. tested up to 1000 V AC.



1

SMARTLY PUT TOGETHER

- The VDE HYBRID tool assortment includes hand tools specially tailored to work in electric mobility.

2

WELL PROTECTED

- All tools are protective insulated according to EN 60900/EC 60900, i.e. tested up to 1000 V AC.

3

SAFELY STORED

- The entire range is stowed in a GEDORE L-BOXX for easy transport.

4

PROFESSIONAL VDE RATCHET

- The GEDORE VDE reversible ratchet in 3/8" ensures a secure hold of the slip-on tools thanks to the push-button lock and offers insulation up to 1000 V.



A complete tool set for the electrician or mechanic on EVs. There is everything in it, in the best quality.

1100-1094

VDE INSULATED TOOL ASSORTMENT HYBRID

53 pieces

- > The perfect range of tools for repair and maintenance work on hybrid and electric vehicles
- > Suitable for vehicles of all manufacturers
- > All tools insulated according to EN 60900/EC 60900
- > GEDORE L-BOXX® 136 compatible with the Sortimo® in-vehicle equipment in your service mobile

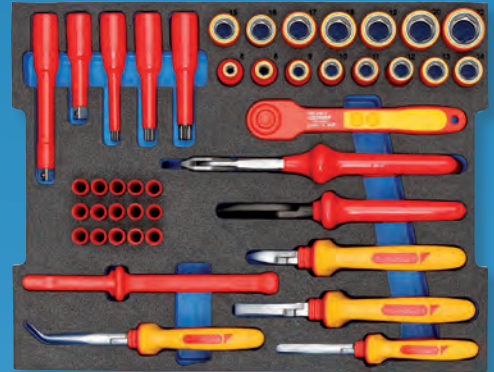

Code	No.	Contents	Length mm	Width mm	Height mm	Pieces	Price	Promotion Price
2979063	1100-1094	3/8" VDE socket No. VDE 30, SW 6 8 9 10 11 12 13 14 15 16 17 18 19 20 22 mm 3/8" VDE screwdriver bit No. VDE INX 30, SW 8 10 12 mm 3/8" VDE extension No. VDE 3090 -3 -6, 75 150 mm 3/8" VDE reversible ratchet No. VDE 3093 U VDE Screwdriver, slotted No. VDE 2170, 2.5 3.5 4 5.5 mm VDE Screwdriver cross recess No. VDE 2160 PH 1 2 3 VDE Screwdriver TX No. VDE 2163 TX T20 T25 T30 VDE Cable shears No. VDE 8094, 200 mm VDE Universal pliers No. VDE 146 10, 10" VDE Power combination pliers No. VDE 8250-200 H, 200 mm 2K-handle VDE Power side cutters No. VDE 8314-180 H, 180 mm VDE Flat nose pliers No. VDE 8132 AB-200 JC, 200 mm angled 2C-handle VDE Flat nose pliers No. VDE 8120-160 H, 160 mm 2K-handle VDE cable knife No. VDE 4522, 180 mm Counter grommet No. V 914, size 1 2 3 + GEDORE L-BOXX®	443	360	155	53	1,295.00	1,165.00



Scan for video

Butler Bros Contact information:

Customer Service: (888) 784-6875
sales@butlerbros.com

Accounts Receivables: receivables@butlerbros.com
Accounts Payables: payabales@butlerbros.com

Locations:

Main Branch (HQ) 2001 Lisbon St.
Lewiston, ME 04240

Massachusetts 75C York Ave.
Randolph, MA 02368

New Hampshire 276 Newport Rd.
STE 201
New London, NH 03257

New York 6295 E. Molloy Rd.
Syracuse, NY 13057

North Carolina 4524 Green Point Dr.
Greensboro, NC 27410

Free freight on order over \$1,500.
Please contact your Butler Rep. for
additional terms and conditions.



Prices valid until 12.31.2023 - Terms and Conditions apply

Brands of the GEDORE Group
gedore.com · ochsenkopf.com
gedore.com